



DOC024.52.93127

ORBISPHERE Model 31x9x & 31285 Thermal Conductivity Sensors

USER MANUAL

8/2024, Edition 7

Section 1 General Information	3
1.1 Disclaimer	3
1.2 Safety information	3
1.2.1 Use of hazard information	3
1.2.2 Service and repairs	3
1.2.3 Precautionary labels.....	4
1.3 Product recycling information.....	5
1.4 Product disposal	7
1.5 Restriction of hazardous substances (RoHS).....	8
Section 2 Technical Specifications	9
2.1 Sensor product line	9
2.2 Sensor weight and dimensions	10
2.3 Sensor certifications.....	10
2.4 Purge gas pressure regulator	10
2.5 TC sensors and parts used on ORBISPHERE configured systems	11
2.6 Sensor membrane specifications.....	12
2.6.1 In-line instrument applications (Table 1)	12
2.6.2 In-line instrument applications (Table 2).....	13
Section 3 Introduction	15
3.1 What you have received	15
3.1.1 Sensor maintenance kit.....	15
3.1.2 TC sensor for CO ₂ , N ₂ or H ₂ measurement.....	15
3.2 Storage information.....	16
3.2.1 Instructions for sensor storage:.....	16
3.3 Thermal conductivity principles.....	17
3.3.1 Definitions	17
3.3.2 Thermal conductivity of gases.....	17
3.3.3 Principle of measurement	17
3.4 Measurement cycle.....	19
Section 4 Installation	21
4.1 Pre-installation	21
4.2 Positioning information.....	21
4.3 Sensor insertion	22
4.4 Sensor removal	22
4.5 Purge gas system	23
4.5.1 ORBISPHERE purge gas regulator	23
4.5.2 Purge gas supply	23
4.6 Mounting accessories	24
4.6.1 Purge safety backup unit.....	24
4.6.2 In-line temperature sensor	24
4.6.3 External pressure sensor	24
4.6.4 Weld-on stainless steel socket.....	25
4.6.5 Insertion/extraction valve	25
4.6.6 ORBISPHERE flow chambers	26
4.6.7 Multi parameter flow chamber.....	28
Section 5 Maintenance	29
5.1 Sensor service	29
5.1.1 Maintenance schedule	29
5.1.2 Testing the sensor condition	29
5.2 Membrane replacement.....	30
5.2.1 Removing the membrane.....	30
5.2.2 Installing the membrane.....	31
Section 6 Spare Parts and Accessories	33

Table of Contents

6.1 Sensor parts	33
6.2 Accessories	33
6.3 Flow chambers and installation devices.....	34
6.4 Maintenance kits for TC sensors.....	34
6.5 Protection caps and related part kits	35

Section 1 General Information

1.1 Disclaimer

The information in this manual has been carefully checked and is believed to be accurate. However, Hach Lange assumes no responsibility for any inaccuracies that may be contained in this manual. In no event will Hach Lange be liable for direct, indirect, special, incidental, or consequential damages resulting from any defect or omission in this manual, even if advised of the possibility of such damages. In the interest of continued product development, Hach Lange reserves the right to make improvements in this manual and the products it describes at any time, without notice or obligation.

1.2 Safety information

Please read the entire manual before unpacking, setting up, or operating this analyzer.

Pay particular attention to all warning and caution statements. Failure to do so could result in serious injury to the operator or damage to the equipment.

To ensure the protection provided by this equipment is not impaired, do not use or install this equipment in any manner other than that which is specified in this manual.

1.2.1 Use of hazard information

⚠ DANGER
Indicates a potentially or imminently hazardous situation which, if not avoided, will result in death or serious injury.
⚠ WARNING
Indicates a potentially or imminently hazardous situation which, if not avoided, could result in death or serious injury.
⚠ CAUTION
Indicates a potentially or imminently hazardous situation that may result in minor or moderate injury.
NOTICE
Indicates a situation which, if not avoided, may cause damage to the instrument. Information that requires special emphasis.

1.2.2 Service and repairs





None of the sensor's components can be repaired by the user. Only personnel from Hach or its approved representative(s) is (are) authorized to attempt repairs to the sensor and only components formally approved by the manufacturer should be used.

Any attempt at repairing the sensor in contravention of these principles could cause damage to the sensor and corporal injury to the person carrying out the repair. It renders the warranty null and void and could compromise the correct working of the sensor and the electrical integrity or the CE compliance of the sensor.

If you have any problems with installation, or using the sensor please contact the company that sold it to you. If this is not possible, or if the results of this approach are not satisfactory, please contact the Customer Service department of Hach.

1.2.3 Precautionary labels

Read all labels and tags attached to the analyzer. Personal injury or damage to the analyzer could occur if not observed.

	This symbol, when noted on a product, indicates a potential hazard which could cause serious personal injury and/or death. The user should reference this instruction manual for operation and/or safety information.
	This symbol, when noted on the product, indicates the presence of devices sensitive to electrostatic discharge and indicates that care must be taken to prevent damage to them.
	This symbol, when noted on the product, identifies a risk of chemical harm and indicates that only individuals qualified and trained to work with chemicals should handle chemicals or perform maintenance on chemical delivery systems associated with the equipment.
	Electrical equipment marked with this symbol may not be disposed of in European public disposal systems. In conformity with European local and national regulations, European electrical equipment users must now return old or end-of-life equipment to the manufacturer for disposal at no charge to the user.
	Products marked with this symbol indicates that the product contains toxic or hazardous substances or elements. The number inside the symbol indicates the environmental protection use period in years.

1.3 Product recycling information

	<p>ENGLISH</p> <p>Electrical equipment marked with this symbol may not be disposed of in European public disposal systems after 12 August 2005. In conformity with European local and national regulations (EU Directive 2002/96/EC), European electrical equipment users must now return old or end-of-life equipment to the manufacturer for disposal at no charge to the user.</p> <p>Note: <i>For return for recycling, please contact the equipment manufacturer or supplier for instructions on how to return end-of-life equipment for proper disposal.</i></p>
<p>DEUTSCH</p> <p>Elektrogeräte, die mit diesem Symbol gekennzeichnet sind, dürfen in Europa nach dem 12. August 2005 nicht mehr über die öffentliche Abfallentsorgung entsorgt werden. In Übereinstimmung mit lokalen und nationalen europäischen Bestimmungen (EU-Richtlinie 2002/96/EC), müssen Benutzer von Elektrogeräten in Europa ab diesem Zeitpunkt alte bzw. zu verschrottende Geräte zur Entsorgung kostenfrei an den Hersteller zurückgeben.</p> <p>Hinweis: <i>Bitte wenden Sie sich an den Hersteller bzw. an den Händler, von dem Sie das Gerät bezogen haben, um Informationen zur Rückgabe des Altgeräts zur ordnungsgemäßen Entsorgung zu erhalten.</i></p>	
<p>FRANCAIS</p> <p>A partir du 12 août 2005, il est interdit de mettre au rebut le matériel électrique marqué de ce symbole par les voies habituelles de déchetterie publique. Conformément à la réglementation européenne (directive UE 2002/96/EC), les utilisateurs de matériel électrique en Europe doivent désormais retourner le matériel usé ou périmé au fabricant pour élimination, sans frais pour l'utilisateur.</p> <p>Remarque: <i>Veillez vous adresser au fabricant ou au fournisseur du matériel pour les instructions de retour du matériel usé ou périmé aux fins d'élimination conforme.</i></p>	
<p>ITALIANO</p> <p>Le apparecchiature elettriche con apposto questo simbolo non possono essere smaltite nelle discariche pubbliche europee successivamente al 12 agosto 2005. In conformità alle normative europee locali e nazionali (Direttiva UE 2002/96/EC), gli utilizzatori europei di apparecchiature elettriche devono restituire al produttore le apparecchiature vecchie o a fine vita per lo smaltimento senza alcun costo a carico dell'utilizzatore.</p> <p>Nota: <i>Per conoscere le modalità di restituzione delle apparecchiature a fine vita da riciclare, contattare il produttore o il fornitore dell'apparecchiatura per un corretto smaltimento.</i></p>	
<p>DANSK</p> <p>Elektriske apparater, der er mærket med dette symbol, må ikke bortskaffes i europæiske offentlige affaldssystemer efter den 12. august 2005. I henhold til europæiske lokale og nationale regler (EU-direktiv 2002/96/EF) skal europæiske brugere af elektriske apparater nu returnere gamle eller udtjente apparater til producenten med henblik på bortskaffelse uden omkostninger for brugeren.</p> <p>Bemærk: <i>I forbindelse med returnering til genbrug skal du kontakte producenten eller leverandøren af apparatet for at få instruktioner om, hvordan udtjente apparater bortskaffes korrekt.</i></p>	

SVENSKA

Elektronikutrustning som är märkt med denna symbol kanske inte kan lämnas in på europeiska offentliga sopstationer efter 2005-08-12. Enligt europeiska lokala och nationella föreskrifter (EU-direktiv 2002/96/EC) måste användare av elektronikutrustning i Europa nu återlämna gammal eller uttrangerad utrustning till tillverkaren för kassering utan kostnad för användaren.

Obs! Om du ska återlämna utrustning för återvinning ska du kontakta tillverkaren av utrustningen eller återförsäljaren för att få anvisningar om hur du återlämnar kasserad utrustning för att den ska bortskaffas på rätt sätt.

ESPAÑOL

A partir del 12 de agosto de 2005, los equipos eléctricos que lleven este símbolo no deberán ser desechados en los puntos limpios europeos. De conformidad con las normativas europeas locales y nacionales (Directiva de la UE 2002/96/EC), a partir de esa fecha, los usuarios europeos de equipos eléctricos deberán devolver los equipos usados u obsoletos al fabricante de los mismos para su reciclado, sin coste alguno para el usuario.

Nota: *Sírvase ponerse en contacto con el fabricante o proveedor de los equipos para solicitar instrucciones sobre cómo devolver los equipos obsoletos para su correcto reciclado.*

NEDERLANDS

Elektrische apparatuur die is voorzien van dit symbool mag na 12 augustus 2005 niet meer worden afgevoerd naar Europese openbare afvalsystemen. Conform Europese lokale en nationale wetgeving (EU-richtlijn 2002/96/EC) dienen gebruikers van elektrische apparaten voortaan hun oude of afgedankte apparatuur kosteloos voor recycling of vernietiging naar de producent terug te brengen.

Nota: *Als u apparatuur voor recycling terugbrengt, moet u contact opnemen met de producent of leverancier voor instructies voor het terugbrengen van de afgedankte apparatuur voor een juiste verwerking.*

POLSKI

Sprzęt elektryczny oznaczony takim symbolem nie może być likwidowany w europejskich systemach utylizacji po dniu 12 sierpnia 2005. Zgodnie z europejskimi, lokalnymi i państwowymi przepisami prawa (Dyrektywa Unii Europejskiej 2002/96/EC), użytkownicy sprzętu elektrycznego w Europie muszą obecnie przekazywać Producentowi stary sprzęt lub sprzęt po okresie użytkowania do bezpłatnej utylizacji.

Uwaga: *Aby przekazać sprzęt do recyklingu, należy zwrócić się do producenta lub dostawcy sprzętu w celu uzyskania instrukcji dotyczących procedur przekazywania do utylizacji sprzętu po okresie użytkowania.*

PORTUGUES

Qualquer equipamento eléctrico que ostente este símbolo não poderá ser eliminado através dos sistemas públicos europeus de tratamento de resíduos sólidos a partir de 12 de Agosto de 2005. De acordo com as normas locais e europeias (Directiva Europeia 2002/96/EC), os utilizadores europeus de equipamentos eléctricos deverão agora devolver os seus equipamentos velhos ou em fim de vida ao produtor para o respectivo tratamento sem quaisquer custos para o utilizador.

Nota: *No que toca à devolução para reciclagem, por favor, contacte o produtor ou fornecedor do equipamento para instruções de devolução de equipamento em fim de vida para a sua correcta eliminação.*

1.4 Product disposal

Note: The following only applies to European customers.

Hach is committed to ensuring that the risk of any environmental damage or pollution caused by any of its products is minimized as far as possible. The European Waste Electrical and Electronic Equipment (WEEE) Directive (2002/96/EC) that came into force on August 13 2005 aims to reduce the waste arising from electrical and electronic equipment; and improve the environmental performance of all those involved in the life cycle of electrical and electronic equipment.



In conformity with European local and national regulations (EU Directive 2002/96/EC stated above), electrical equipment marked with the above symbol may not be disposed of in European public disposal systems after 12 August 2005.

Hach will offer to take back (**free of charge to the customer**) any old, unserviceable or redundant analyzers and systems which carry the above symbol, and which were originally supplied by Hach. Hach will then be responsible for the disposal of this equipment.

In addition, Hach will offer to take back (**at cost to the customer**) any old, unserviceable or redundant analyzers and systems which do not carry the above symbol, but which were originally supplied by Hach. Hach will then be responsible for the disposal of this equipment.

Should you wish to arrange for the disposal of any piece of equipment originally supplied by Hach, please contact your supplier or our After Sales Service department in Geneva for instructions on how to return this equipment for proper disposal.

1.5 Restriction of hazardous substances (RoHS)

The European Union RoHS Directive and subsequent regulations introduced in member states and other countries limits the use of six hazardous substances used in the manufacturing of electrical and electronic equipment.

Currently, monitoring and control instruments do not fall within the scope of the RoHS Directive, however Hach has taken the decision to adopt the recommendations in the Directive as the target for all future product design and component purchasing.



This product is compliant with the European Union RoHS Directive.

Section 2 Technical Specifications

Specifications are subject to change without notice.

2.1 Sensor product line

⚠ WARNING	
	Handle H₂ gas with great care! It is extremely flammable and explosive

			Sensor Models: Sample Temperature Range 0-50°C Standby Temperature Range 0-120°C	
Gas	Purge gas	Calibration gas	Standard (20 Bar Rated)	High Pressure (170 Bar Rated)
H ₂	N ₂	pure H ₂	31290TC	31290HP
	Argon		31291TC	-
	CO ₂		31292TC	31292HP
H ₂ /He	Clean air	air or pure H ₂ or pure He	31285TC	-
D ₂ /He	Clean air	air or pure D ₂ or pure He	31285TC	-
CO ₂	N ₂	pure CO ₂	31490TC	-
N ₂	CO ₂	pure N ₂	31590TC	31590HP
	H ₂		31591TC	31591HP
	Argon		31593TC	31593HP
	He		31594TC	31594HP

All ORBISPHERE thermal conductivity sensor enclosures are certified IP68

2.2 Sensor weight and dimensions

Refer to [Table 5 on page 12](#) and [Table 6 on page 13](#) for membrane applications. The weight of the TC sensor is 1050 g (± 20 g).

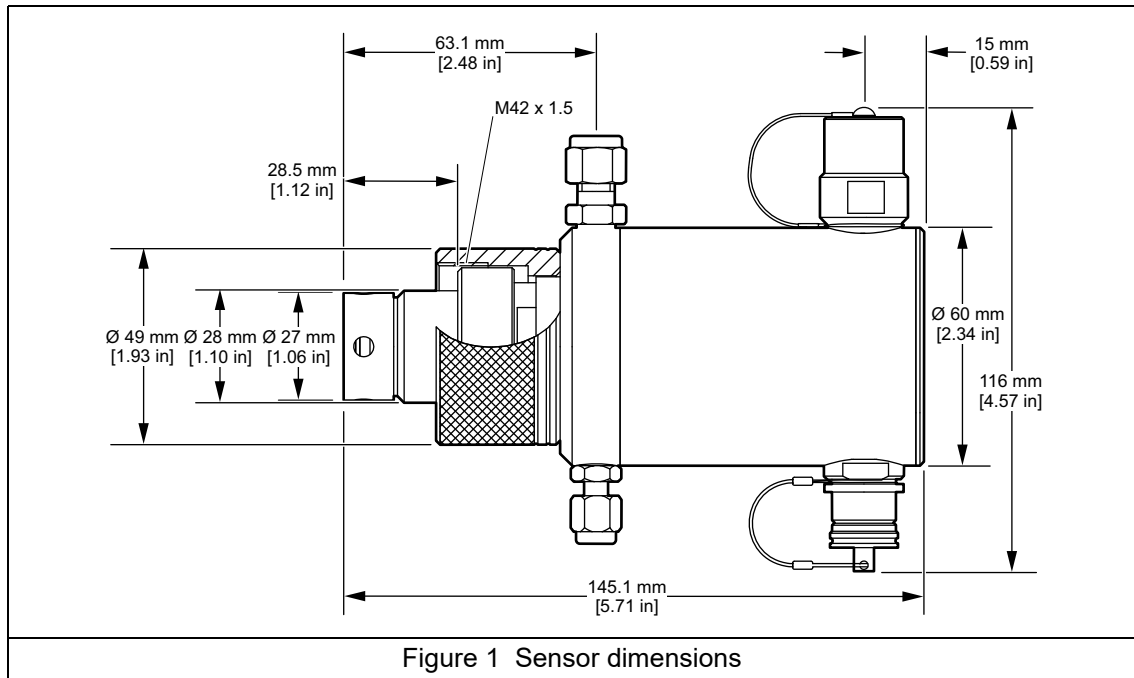

Figure 1 Sensor dimensions

2.3 Sensor certifications

Table 2 CE certifications	
CE certification	EN61326-1: EMC Directive

2.4 Purge gas pressure regulator

Table 3 Purge gas regulator specifications	
Model	29089S4 (0.25 in.), 29089S6 (6 mm)
Filtration grade	40 μ m
Input pressure min/max	1 bar / 16 bar
Output pressure min/max	0.5 bar / 7 bar
Standard nominal flow rate	900 Liters/minute
Condensate volume	22 cm ³
Temperature range (ambient and media)	-10°C to 60°C
Purge gas dew point	-10°C (+14°F)
Construction materials	Housing: metal Condensate bowl: polycarbonate Bowl guard: metal
Weight	460 g.
Size in cm (overall)	21 x 11.5 x 8

2.5 TC sensors and parts used on ORBISPHERE configured systems

Table 4 ORBISPHERE configured systems						
Configured System	Gas	Sensor	Membrane	Holding Ring	Protection Cap *	Maint. Kit
3625 Package Analyzer	CO ₂	31490TC	1 x 29561A	29228	29111	32760
	N ₂	31590				
3624 ProBrix	CO ₂	31490TC	1 x 29561A	29228	29108	32749 (includes kit 29082)
Analyzer 410	CO ₂	3119x	1 x 29561A	29228	29108	32749 (includes kit 29082)
Analyzers 51x 3610 3620 3621 3622 3623	CO ₂	3149x	1 x 29561A	29228	29108	32749 (includes kit 29082)
	N ₂	3159x				
	H ₂ (0 to 1.5 bar)	3129x	1 x 29561A	29229	29108	32739 (includes kit 29082)
	H ₂ (0 to 6 bar)		1 x 2952A			32741 (includes kit 29082)

Note: * Refer to [Table 12 on page 35](#) for See about protection caps and related parts.

2.6 Sensor membrane specifications

2.6.1 In-line instrument applications (Table 1)

Table 5 In-line applications (1)			
Sensor Type	31290 H₂ (purge gas N₂) For other purge gases, please contact your Hach representative for specification.		
Membranes	29561A	2952A	2935A
Thickness	25 µm	25 µm	25 µm
Membrane material	PFA	ETFE	ECTFE (Halar)
Recommended applications	Waste gas offgas, reactor coolant	Reactor coolant	High H ₂ level
Radiation limits	10 ⁵ rad	10 ⁸ rad	10 ⁸ rad
Measurement range at 25°C	0-2 ppm, or 0-25 cc/kg, or 0-1.5 bar	0-10 ppm, or 0-120 cc/kg, or 0-6 bar	0-20 ppm, or 0-220 cc/kg, or 0-12 bar
Accuracy (sample temp. 20-50°C within ± 5°C of calibration temperature)	The greater of ±1% of reading or ± 2 ppb, or ± 0.03cc/kg, or ± 1.5 mbar	The greater of ±1% of reading or ± 8 ppb, or ± 0.1cc/kg, or ± 6 mbar	The greater of ±1% of reading or ± 25 ppb, or ± 0.4 cc/kg, or ± 20 mbar
Accuracy (sample temp. 0-50°C independent of calibration temperature)	The greater of ±3% of reading or ± 15 ppb or ± 0.18 cc/kg or ± 6 mbar	The greater of ±3% of reading or ± 60 ppb or ± 0.6 cc/kg, or ± 20 mbar	The greater of ±3% of reading or ± 150 ppb or ± 2.5 cc/kg, or ± 50 mbar
Measurement cycle (sec.)	17		
Sample flow rate (through flow chamber) ¹	500 mL/min	200 mL/min	100 mL/min
Linear flow rate (past sensor socket) ²	N/A	N/A	N/A

2.6.2 In-line instrument applications (Table 2)

Table 6 In-line applications (2)				
Sensor Type	31490 CO ₂ (purge gas N ₂)	31590 N ₂ (purge gas CO ₂)	31285TC H ₂ /D ₂ and He (clean air purge)	
Membranes	29561A	29561A	2952A	29561A
Thickness	25 µm	25 µm	25 µm	25 µm
Membrane material	PFA	PFA	ETFE	PFA
Recommended applications	In-line beverage	In-line beverage	Reactor coolant	Waste gas PWR
Radiation limits	10 ⁵ rad	10 ⁵ rad	10 ⁸ rad	10 ⁵ rad
Measurement range at 25°C	0-7 V/V, or 0-15 g/kg, or 0-10 bar	0-350 ppm, or 0-300 ml/l, or 0-20 bar	0-100% H ₂ /D ₂ or 0-10 bar	0-100% H ₂ /D ₂ or 0-4 bar
Accuracy (sample temp. 20-50°C within ± 5°C of calibration temperature)	The greater of ±1% of reading or ± 0.006V/V, or ± 0.012g/kg, or ± 8 mbar	The greater of ±2% of reading or ± 0.3 ppm, or ± 0.25ml/l, or ± 15 mbar	The greater of ±2% of reading or ± 1% H ₂ /D ₂	The greater of ±2% of reading or ± 0.2% H ₂ /D ₂
Accuracy (sample temp. 0-50°C independent of calibration temperature)	The greater of ±2% of reading or ± 0.02 V/V or ± 0.048g/kg or ± 14 mbar	The greater of ±4% of reading or ± 1 ppm or ± 0.8 ml/l or ± 34 mbar	N/A	N/A
Measurement cycle (sec.)	22 ³		60	60
Sample flow rate (through flow chamber) ¹	100 ml/min	300 ml/min	200 ml/min	500 ml/min
Linear flow rate (past sensor socket) ²	50 cm/sec	150 cm/sec	N/A	N/A

¹ Minimal flow through an ORBISPHERE 32001 flow chamber.

² Minimal flow past an ORBISPHERE 29501 sensor socket

³ Measurement cycle for 3624 ProBrix application is 15 seconds.

Section 3 Introduction

NOTICE

Do not place the sensor into a liquid sample until the purge gas system is in operation and connected to an instrument that is turned on. If purge gas does not circulate, moisture can build up inside the sensor and damage it.

3.1 What you have received

Check that all mounting hardware is included in shipment. Note that, unless the sensor is part of an ORBISPHERE complete system, the sensor must be installed in an ORBISPHERE socket or flow chamber that allows contact with the sample flow. Refer to [Installation on page 21](#) for details.

3.1.1 Sensor maintenance kit

The maintenance kit includes the material needed to service and maintain the sensor.

3.1.2 TC sensor for CO₂, N₂ or H₂ measurement

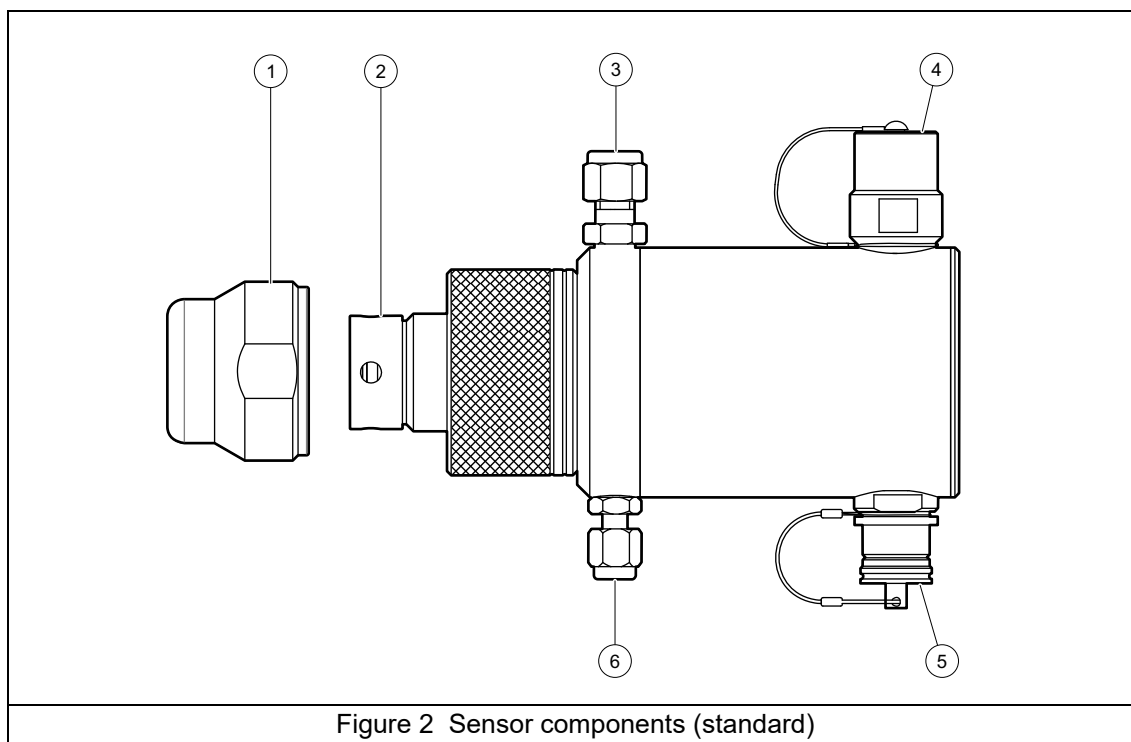

Figure 2 Sensor components (standard)

1.	Storage cap
2.	Protection cap
3.	Purge gas inlet
4.	Output connection to instrument
5.	Input connection from the optional in-line temperature sensor
6.	Purge gas outlet

The sensor head is protected by a screw-on plastic storage cap. The sensor can connect to an optional in-line temperature sensor (no.5 in [Figure 2 on page 15](#)) that allows you to install a temperature sensor directly into the sample flow.

The sensor has been carefully checked and calibrated in a production environment and following our quality control procedures. As such, there is no need for any sensor maintenance or a change of membrane, prior to installation. An easily removed label is stuck on the protection cap to remind you of this.

Two small identification clips (stamped with the letter “T”) will be delivered with every sensor. They should be used to identify the connection cable between the sensor and a multi-channel analyzer. This is important in order to avoid connecting the sensor to the wrong measurement board. Connecting a TC sensor to an EC measurement board (and vice versa) can damage both the sensor and the electronics.

3.2 Storage information

NOTICE

We recommend you use the ORBISPHERE 32605 Purge safety backup unit to ensure that the purge gas supply to the sensor will not get interrupted in case of a mains power outage. Refer to [Purge safety backup unit on page 24](#).

During a short shutdown period (such as weekends), the sensor may stay in place with the instrument turned on, and purge gas supplied. If the inactive period is likely to last longer, remove the sensor, wipe it dry and store it properly, using the plastic storage cap supplied.

3.2.1 Instructions for sensor storage:

NOTICE

Pay attention to rapid temperature change situations, such as air conditioning being turned on and off daily, that may create condensation inside the sensor's cell and damage the electronics inside.

- If the sensor's head shows deposits, rinse it under tap water.
- Wipe the sensor head dry.
- Put a small silica desiccant bag inside the storage cap.
- Put the storage cap in place.
- Store the sensor in a safe dry place.
- The storage place must be at a stable room temperature.

3.3 Thermal conductivity principles

3.3.1 Definitions

The thermal conductivity of a gas is defined as the heat (in calories) transferred for one second in this gas, between two 1 cm^2 surfaces placed 1 cm apart, when the temperature difference between these two surfaces is 1°C .

In more general terms, the thermal conductivity of a gas is the ability of this gas to transfer heat.

3.3.2 Thermal conductivity of gases

Each gas has a different thermal conductivity. Only gases having distinct thermal conductivity rates can be detected using this method. Therefore the system is able to measure a gas concentration in a quasi-binary mixture when this gas has a clearly distinct thermal conductivity rate to the background gas rate.

The sensor's measuring technique is a combination of a gas diffusion membrane and a gas thermal conductivity detector. The small volume enclosed between the diffusion membrane and the thermal conductivity detector is periodically flushed with a purge gas. After each purge, the gas to be measured diffuses from the sample through the membrane, changing the thermal conductivity of the gas surrounding the detector. It is the rate of change of the thermal conductivity that allows the concentration of the gas to be calculated.

3.3.3 Principle of measurement

As a detector, ORBISPHERE thermal conductivity sensors use an electrically heated thermal conductivity chip, separated from the sample by a gas diffusion membrane. Depending on the application, the membrane may be protected by a grille.

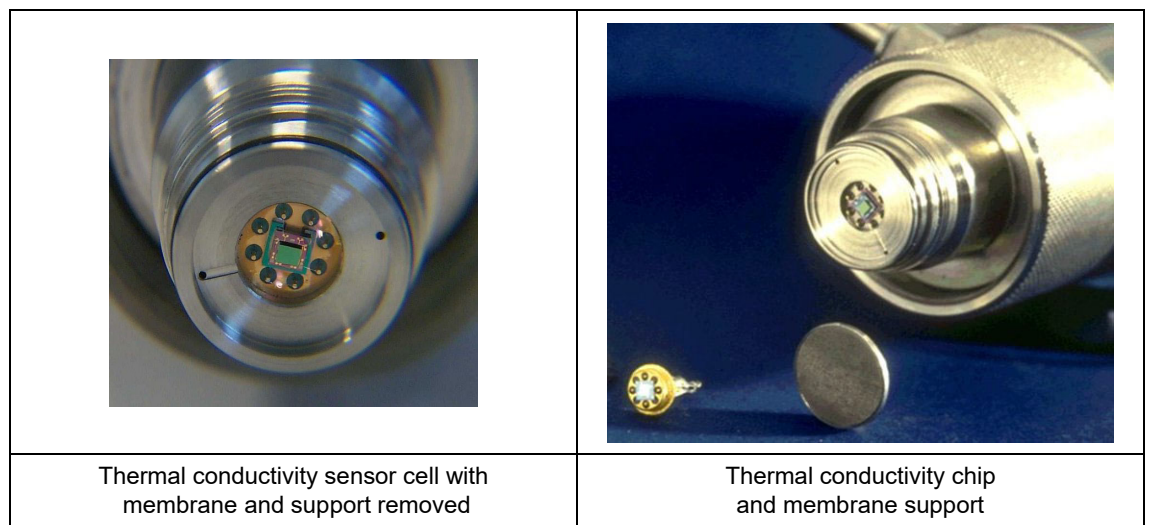

Gas diffuses through a membrane and gets in contact with the chip. The change in thermal conductivity modifies the chip resistivity. A resulting voltage variation at the chip is measured.

A purge gas enters on the left connection, passes through the solenoid valve (when activated), flows through the thermal conductivity chip compartment beneath the membrane, and exits at the outlet on the right.

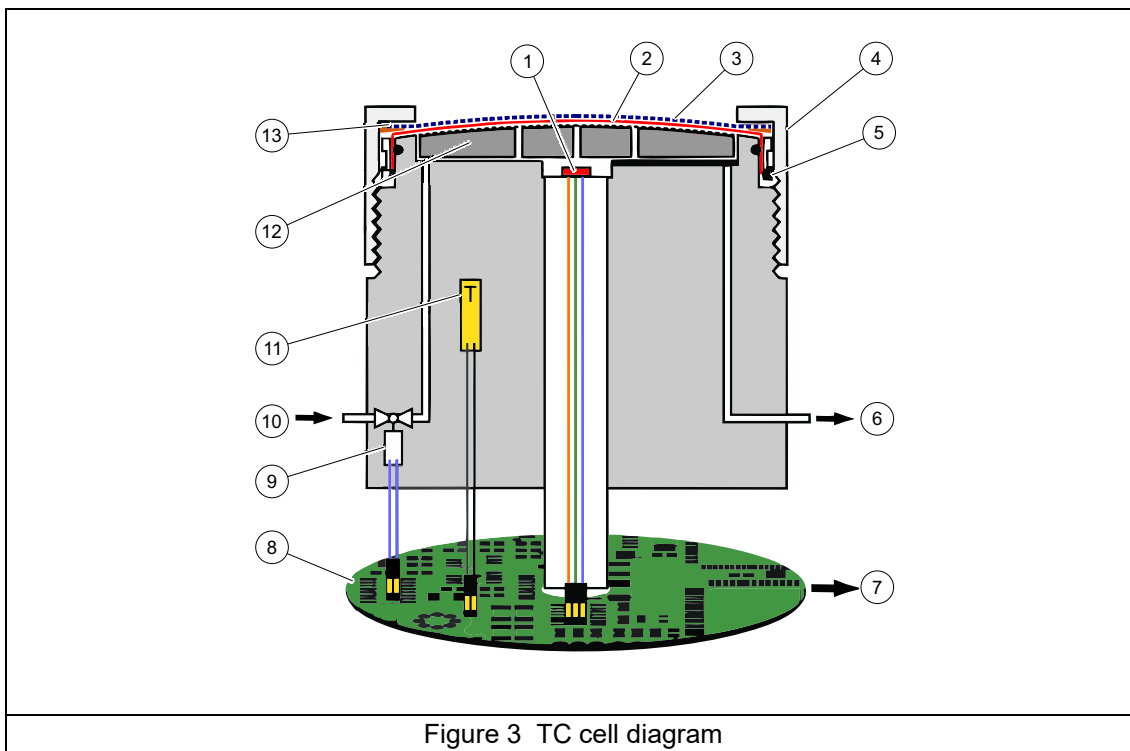

Figure 3 TC cell diagram

1. Thermal conductivity chip	8. Electronic board
2. Membrane	9. Solenoid valve (normally closed)
3. Grille (when applicable)	10. Purge gas inlet
4. Protection cap	11. Temperature sensor
5. Membrane holding ring	12. Membrane support
6. Gas outlet	13. Washers
7. Analogic signal to instrument	

3.4 Measurement cycle

The ORBISPHERE system works on a two-cycle sequence (approx. 20 sec.), with one reference update per sequence. The sequence consists of one purge cycle and one sampling cycle:

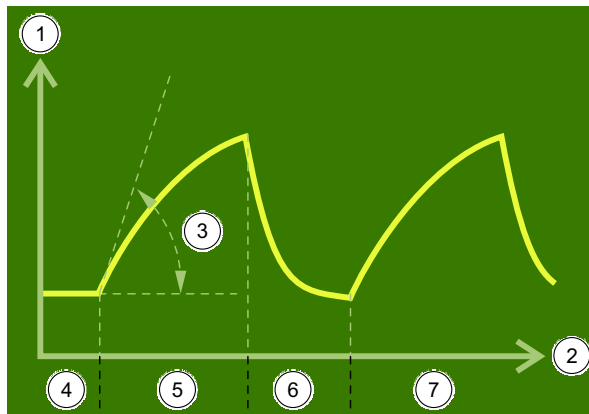
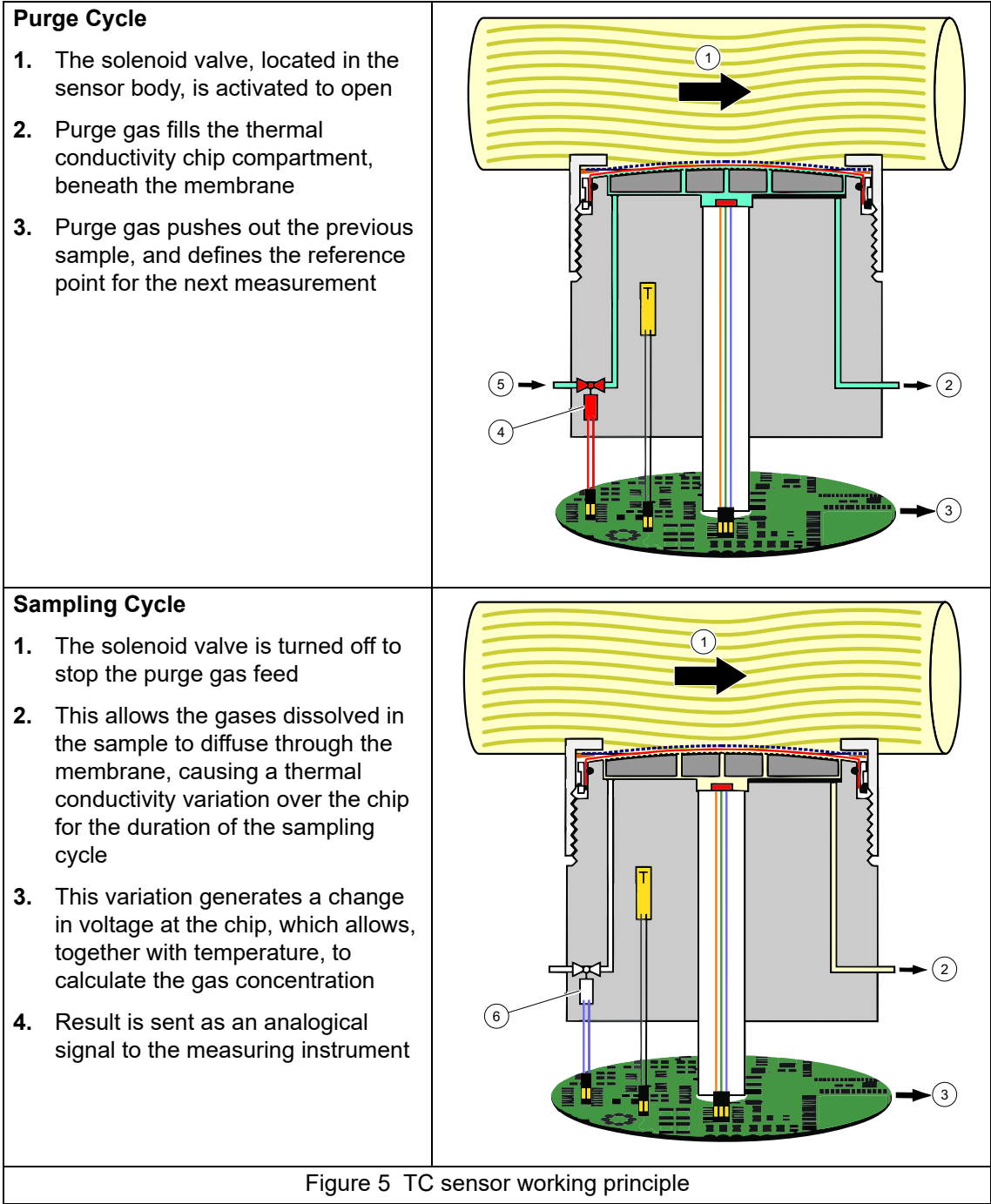

Figure 4 Measurement cycle

1. Signal voltage	5. Sampling
2. Time	6. Purge
3. Initial slope	7. Sampling
4. Purge	



1. Sample flow	4. Solenoid valve open
2. Purge gas outlet	5. Purge gas inlet
3. Analogic signal to instrument	6. Solenoid valve closed

Section 4 Installation

4.1 Pre-installation

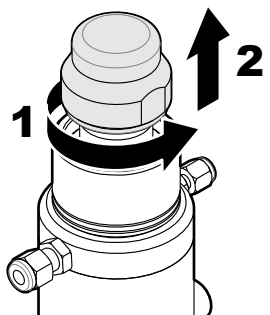
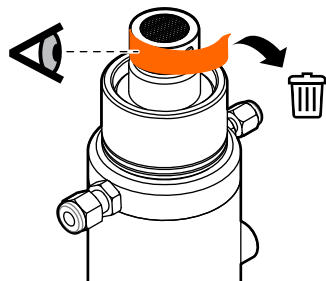
<p>1. The sensor head is protected by a screw-on black plastic storage cap. This cap should be removed.</p>	
<p>2. Once the storage cap has been removed, an orange sticker will be visible informing you not to remove the protection cap. This is because the sensor has already been checked and calibrated prior to shipping, and no sensor maintenance or membrane change is required prior to first use. However, this label must be removed.</p>	
<p>3. Attach the two small identification clips (stamped with the letter "T") to each end of the sensor cable so they are clearly visible. These clips indicate this is a TC sensor, so when connecting to a multi-channel analyzer, care must be taken to connect it to the TC measurement board.</p>	
<p>4. Make sure that the gas purge supply is set to ON before the sensor is installed in a line or a flow chamber that contains liquid or humidity. If the sensor does not have purge gas supply when it is in aqueous liquid or condensing humidity, permanent damage to the sensing element will occur.</p>	

4.2 Positioning information

Unless the sensor is part of an ORBISPHERE complete system, it must be installed in a suitable socket or flow chamber that will allow contact with the sample fluid or gas to be analyzed.

The sensor and measuring instrument are connected via a cable and 10 pin connector. The standard sensor cable length is 3 m.

Check that the sensor will be mounted:

- perpendicular to the pipe.
- horizontal.
- on a horizontal pipe section (or on flow-ascending vertical pipe).
- minimum 15 meters away from pump's discharge side.
- in a place where sample flow is stable and rapid; as far as possible from:
 - valves
 - pipe bends
 - suction side of pumps
 - CO₂ injection system or similar

Note: There may be situations where not all the above conditions can be met. Please consult your Hach representative to appraise the situation and define the best applicable solution.

4.3 Sensor insertion

- Insert the sensor straight into the flow chamber or socket.
- Hand tighten the attaching collar.
- Connect the sensor cables and purge gas supply before inserting.
- Check for leaks; replace O-rings if product leaks are visible.

Instructions for Micro Volume Flow Chambers

Do not twist the sensor when inserting it into a micro volume flow chamber. This rotation may twist the protection cap, thus changing the membrane position. This can modify the membrane measuring conditions, and affect measurement precision.

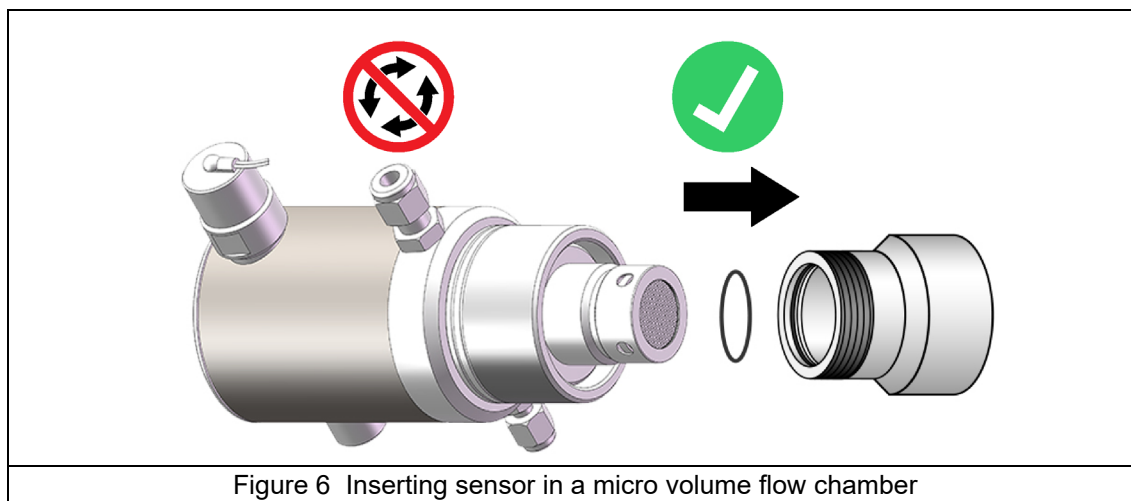

Figure 6 Inserting sensor in a micro volume flow chamber

Note: Check that the small O-ring, located at the bottom of the micro volume flow chamber, is present during removal and installation of the sensor, as it may stick to the sensor head and fall.

4.4 Sensor removal

- Shut off the sample flow and drain the sampling circuit from liquid or gas pressure.
- Remove the sensor cables connected at the sensor side.
- Remove the purge gas connections.
- Hold the sensor body in one hand to avoid rotation, and unscrew the collar with other hand.
- Pull the sensor straight out of its socket, or flow chamber.
- Check that both O-rings remain in place inside the flow chambers.
- Install the storage cap on the sensor.

4.5 Purge gas system

4.5.1 ORBISPHERE purge gas regulator

The role of the ORBISPHERE 29089 gas regulator is to deliver purge gas filtered at 40 μm . Attach the unit to a suitable bracket, using the M3 threaded holes on the back. It's position should be vertical $\pm 5\%$. The gas flow is indicated by an arrow on the regulator's body. Refer to [Purge gas pressure regulator on page 10](#).

Maintenance:

Drain the condensate periodically. Unscrew by hand the drain at the bottom of the bowl.

If filter is contaminated:

- Turn off the gas supply
- Unscrew the bowl by hand
- Unscrew the black disc at the bottom
- Remove the white composite filter
- Wash under clean tap water, blow dry, and install



4.5.2 Purge gas supply

Note: Check the purge gas specifications in [Purge gas pressure regulator on page 10](#) of this manual.

Make sure there is no interruption in the purge gas supply. The use of a backup gas cylinder and an automatic changeover valve, that activates when the first cylinder is empty, are recommended.

Use a 6 mm flexible (nylon or PVC) or rigid (stainless steel) line to connect the pressure regulator and thermal conductivity sensor to the purge gas supply. Swagelok connectors (6 mm or 1/4") are provided.

A short length of plastic tube is supplied for the purge gas to exit the sensor. To insert, push the tube firmly into the orifice. To remove, push on the ring surrounding the tube, and pull the tube out. For certain applications such as waste gas, a 3 mm (1/8") Swagelok fitting is provided for the purge gas exit, to enable safe evacuation of an eventually hazardous gas.

A source of dry and filtered gas (pure at 99.8%) is required with a flow rate set at 10 to 50 ml/min., and a pressure regulated at 2 bar gauge. Do not exceed this, since excess pressure will deform the membrane and change measurements.

To check the flow rate, put the exit tube into a cup of water. With the instrument turned on, you should see at least three bubbles per second during the purge cycle (or select the "Continuous Purge" function in the instrument "Options" menu).

NOTICE

Do not leave the exit tube in water, as there is a risk that moisture will get sucked back into the sensor and damage it.

4.6 Mounting accessories

Note: Check the spare part list at the end of this manual for ordering information.

4.6.1 Purge safety backup unit

The gas analyzer must be switched on at all times, and purge gas must be constantly supplied to purge the sensor cell, to prevent damage to the sensor electronics.

However, in the event of a mains power outage, the 32605 purge backup unit ensures that the purge gas supply to the TC sensor is not interrupted at any time. The cycle is slower than usual (around one minute), for approximately four days.

The green LED is on as long as the battery charge is OK. The red LED is on when charging is needed. To save batteries, both LEDs are out when the backup unit is in use, and mains power is out.



The 32605 purge backup unit is connected between the instrument and the sensor. The internal batteries are automatically charged through the sensor cable when the instrument is turned on.

4.6.2 In-line temperature sensor

The in-line temperature sensors give the sample temperature directly from the sample flow, as a replacement for the temperature sensor installed inside the thermal conductivity sensor.

Use of the in-line temperature sensor is recommended when the environment or sample experience temperature changes. It provides a direct sample temperature measurement to the instrument, that is not influenced by the ambient temperature.

The in-line temperature sensor connects at the rear of the sensor. When connected, the in-line temperature signal bypasses the internal temperature sensor signal, and is sent to the measuring instrument via the thermal conductivity sensor cable as usual. When the in-line temperature sensor is unplugged, the internal temperature sensor is re-activated.

There are a number of different temperature sensors depending on the specific application requirements. Refer to [Table 9 on page 33](#) for the available options.

4.6.3 External pressure sensor

NOTICE

Do NOT exceed the pressure range of the sensor. This would permanently deform the sensor membrane, thus delivering incorrect pressure values in the future.

The system can be fitted with an external pressure sensor. This enables a measure of fraction of gas under variable pressure conditions during gas phase measurement.

The external sensor connects to the ORBISPHERE measuring equipment with a 1 meter cable and a 4 pin connector (an optional extension cable can be used, but total length should not exceed 50 m.).

The external pressure sensor can be installed in the model 32002.xxx multi parameter flow chamber.

4.6.4 Weld-on stainless steel socket

The model 29501 weld-on sensor socket can be used to install a sensor into a stainless steel pipe (min.Ø 50 mm or 2"). When welding the socket to the pipe, check that the setback between the pipe inner diameter and the sensor tip is from 0 to 4 mm (Refert to [Figure 7](#)).

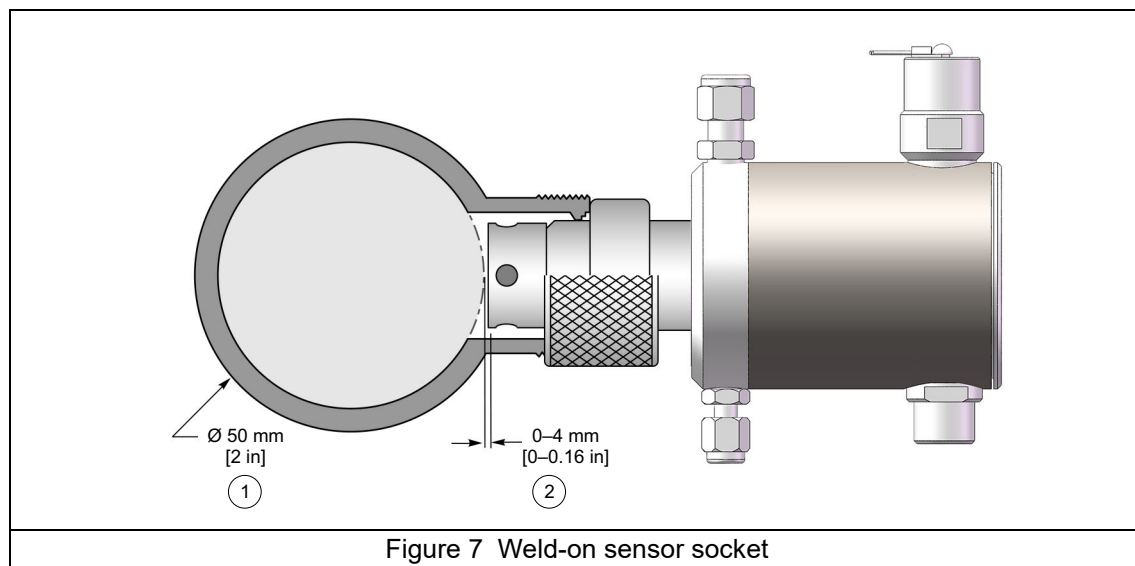

Figure 7 Weld-on sensor socket

1. Minimum pipe diameter	2. Setback allowed from internal pipe diameter
--------------------------	--

Note: Be sure to remove the two O-rings from the socket before welding. Leave the socket stainless steel cap screwed on during welding to prevent thread distortion.

Recommendation:

To facilitate sensor removal and installation, we suggest installing the socket in a location where the liquid can be drained quickly and easily. By creating a one meter long piece of pipe (shown below) with shut off valves at both ends, just a small volume of liquid needs to be drained to enable sensor removal.

Also, a precise sensor and socket installation can be performed in the workshop, and this assembly can be placed in the production line with minimal down time.

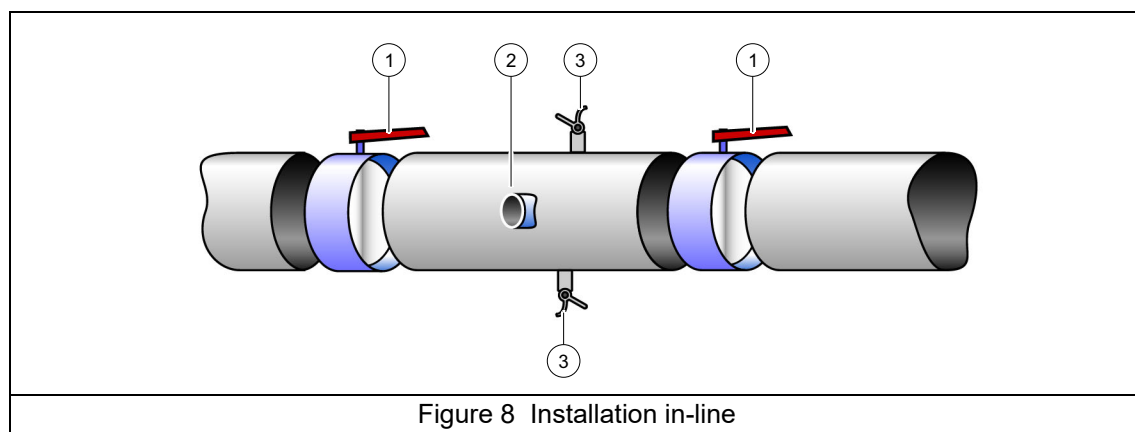

Figure 8 Installation in-line

1. Shut off valve	3. Sampling valve
2. Sensor socket	

4.6.5 Insertion/extraction valve

The ORBISPHERE 32003 insertion/extraction valve allows for sensor removal and installation without having to drain the fluid in the line. It can withstand a pressure of up to 20 bars, with the

sensor in place or not. This device is held in place by a stainless steel clamp to a Tuchenhagen Varivent® In-Line Access Unit.

Sensor insertion is done by aligning the sensor with the valve and tightening the retaining collar until it stops. Removal is done by unscrewing the collar and pulling the sensor out.

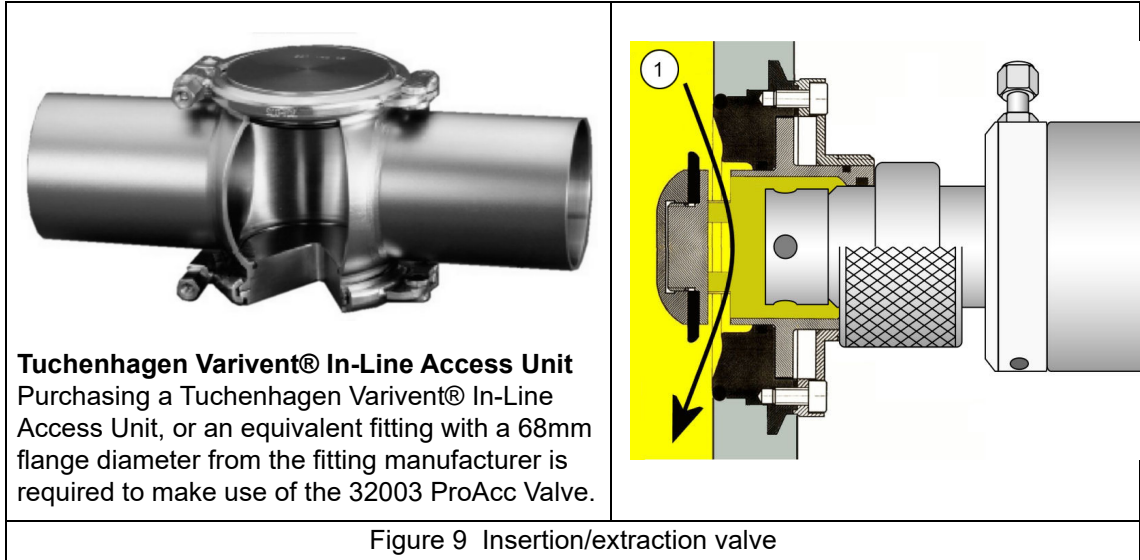

1. Sample flow

Note: This method of installation is OK for a process line where the flow is constant. It is not recommended for applications where the sample flow is stopping and starting.

4.6.6 ORBISPHERE flow chambers

The ORBISPHERE 32001. xxx flow chambers are used to draw liquid and gaseous samples past the sensor. They are available in several materials, depending on the application.

They connect to 6-mm or ¼" stainless steel tubing by means of two Swagelok™ fittings. If necessary, copper or plastic tubing with low permeability can be used. Stainless steel tubing is normally enough to hold the assembly in place, but for a more stable installation, a large U-bolt can be used to mount the flow chamber to a support.

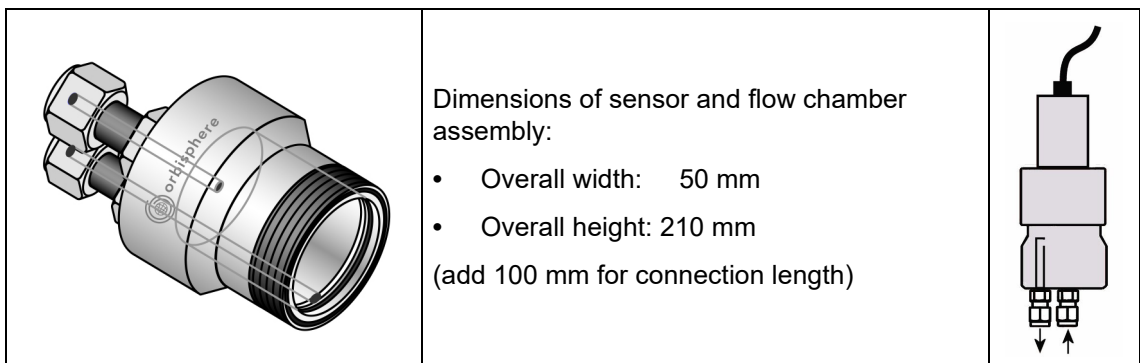

Table 7 Flow chamber orientation		
Sample	Orientation of Flow Chamber	
Gaseous or liquid media	Vertically, with connections down and sensor up: <ul style="list-style-type: none"> Center connection is the inlet Outer connection is the outlet 	
Gaseous media, with occasional liquid or vapor	Horizontally, to allow for drainage: <ul style="list-style-type: none"> Center connection (inlet) must be up Outer connection (outlet) must be down 	

The connection diagram below is a recommended installation that allows for measuring and calibrating without having to disconnect a line manually. "A" and "B" represent 3-way valves.

For measuring, calibration gas inlets and outlets are shut off. During calibration, the flow is reversed to drive the remaining sample out. The calibration gas enters at the "sample out" port and exits at the "sample in" port, as shown below.

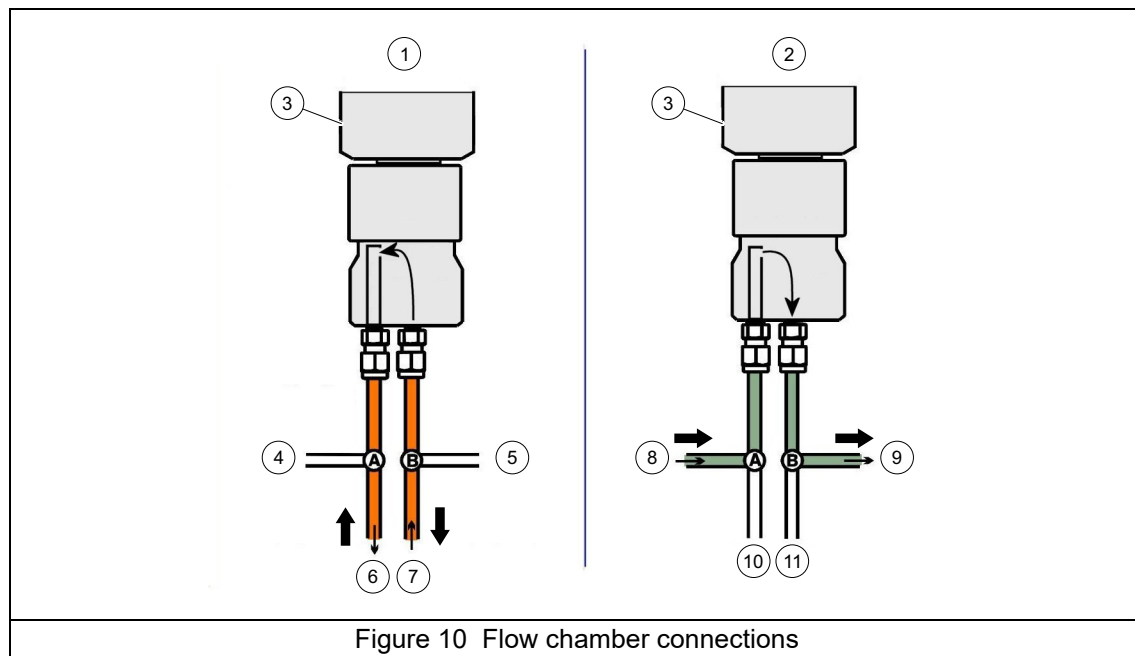

Figure 10 Flow chamber connections

1. Measuring	7. Sample flow in
2. Calibration	8. Calibration gas in
3. Sensor	9. Calibration gas out
4. Calibration gas in shut off	10. Sample flow out shut off
5. Calibration gas out shut off	11. Sample flow in shut off
6. Sample flow out	

4.6.7 Multi parameter flow chamber

Note: Suitable only for gaseous media.

The ORBISPHERE 32002.xxx multi parameter flow chamber can accommodate one or two sensors and one sample pressure sensor. If only one gas sensor is used, the unused socket is plugged with the stainless steel plugs provided (model 28123). The flow chamber is connected to 6 mm or 1/4" stainless steel tubing by two Swagelok™ fittings. If necessary, copper or plastic tubing with low permeability can be substituted.

The flow chamber should be mounted in such a way that the sample outlet port is located at the lowest point to allow condensation to escape with the outgoing gas. Attach the flow chamber to a vertical support with the screws supplied. The pressure sensor must be on top.

Note: A user manufactured spacer (~15 mm thick) may be used between the flow chamber and support for improved access for sensor removal.

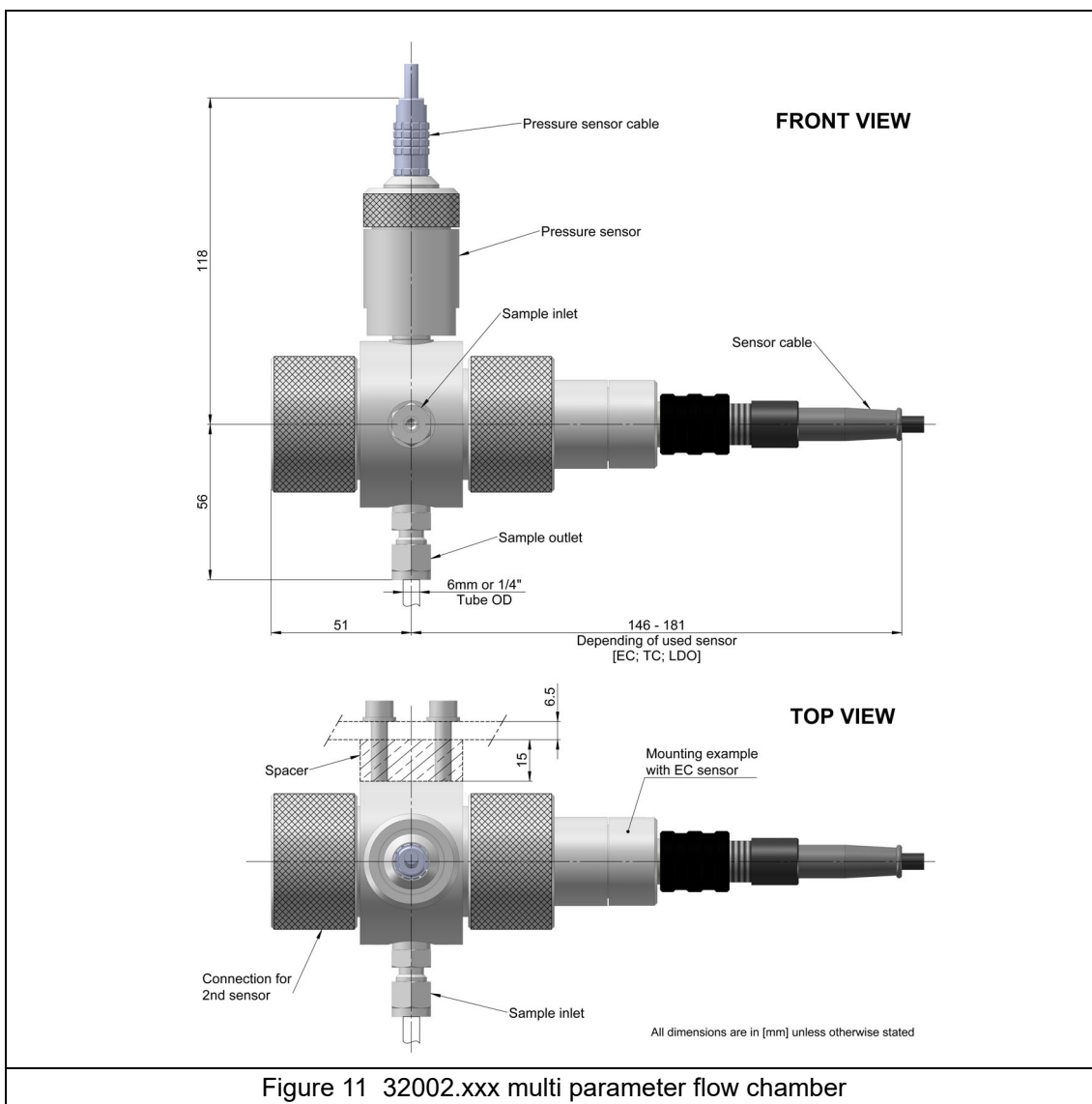

Figure 11 32002.xxx multi parameter flow chamber

1. Top view	5. Front view
2. Sensor	6. Pressure sensor housing
3. Optional second sensor	7. Sample outlet
4. Sample inlet	

Note: Shown here with: gas sensor (right), pressure sensor (center) and optional second sensor (left)

Section 5 Maintenance

5.1 Sensor service

5.1.1 Maintenance schedule

Service includes membrane replacement and external cleaning to restore the original sensor sensitivity. This means low running costs and down time reduced to a minimum.

The membrane needs to be replaced once or twice a year depending on application conditions. This can be tailored accordingly.

Note: *If you are not familiar with ORBISPHERE sensor servicing, your Hach representative will be glad to assist you*

5.1.2 Testing the sensor condition

NOTICE

Carry out the maintenance in a clean dry place in order to avoid damaging the sensor's precision components, and also to prevent water or humidity from getting into the sensor.

Periodically, inspect visually the sensor head for any deposits. Rinse it under clean tap water, and dry with a clean tissue.

To verify the sensor, check measurements vs. a known standard sample value:

- If reading deviation is $\pm 1\%$ of the expected value, no action needs to be taken.
- If deviation exceeds $\pm 1\%$, perform a new calibration.
- If deviation exceeds 10% of the original values, replace the membrane.

5.2 Membrane replacement

5.2.1 Removing the membrane

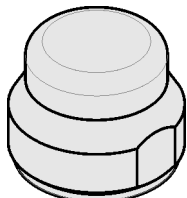
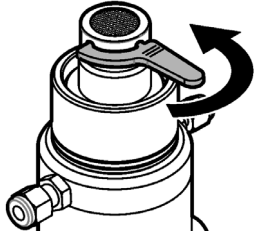
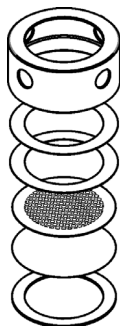
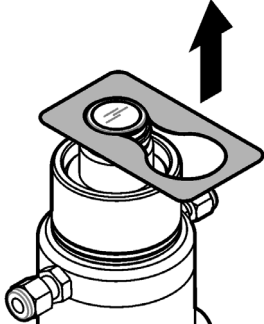

To remove the membrane, follow the steps below:

<p>Place the thermal conductivity sensor vertical with the head up.</p> <p>Remove the plastic storage cap.</p>	
<p>Unscrew the protection cap, using the tool provided in the maintenance kit.</p> <p>CAUTION <i>Never remove the protection cap, unless you plan to replace the membrane.</i></p>	
<p>Pay attention to the components inside the protection cap (Refer to Table 12 on page 35).</p> <p>Note the assembly order of each item.</p> <p>Note: <i>The illustration on the right is an example only. Your configuration may differ.</i></p>	
<p>Pull up the membrane holding ring with the tool provided in the maintenance kit.</p> <p>Remove membrane(s).</p>	

5.2.2 Installing the membrane

Note: For correct membrane selection, please refer to [Sensor membrane specifications on page 12](#).

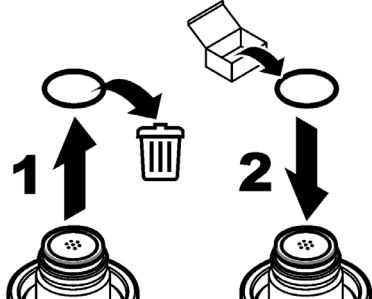
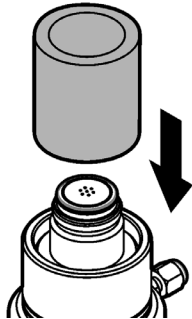
To install the new membrane(s), follow the steps below:

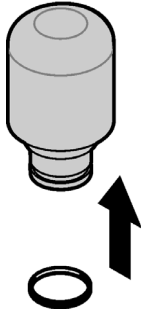
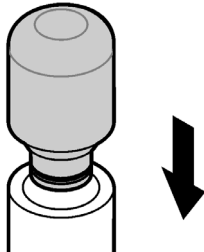
<p>Note: The membrane mounting surface must be clean and even (on top of the sensor, where the membrane and sensor have contact).</p> <p>Replace the membrane O-ring on the sensor head with a new one.</p> <p>Note: The 29039.0 Nitril O-ring can be reused if it is still in good condition. Membrane O-rings are part of the protection cap kit.</p>	
<p>In the maintenance kit, pick up the two part membrane mounting tool.</p> <p>Install the sleeve over the sensor head (end with shoulder downwards).</p> <p>Note: Once installed, a membrane cannot be reused. Avoid touching the membrane with bare fingers, as this may affect its sensitivity.</p>	
<p>Take a few membranes out of the storage box.</p> <p>Using tweezers included in the kit, pick up one membrane from the stack, and gently place it on the sensor tip.</p> <p>Make sure it is centered.</p> <p>Note: Distinguish the membrane from the protection paper: - Membrane is transparent (translucent). - Protection paper is opaque.</p> <p>The membrane diameter is larger than the sensor head diameter. This is normal, as the membrane will fold over the sensor tip.</p>	
<p>Place the membrane holding ring on installation tool tip.</p> <p>CAUTION To avoid damaging the membrane, make sure that the tool tip is totally clean and its surface is even.</p>	
<p>Insert the installation tool inside the guiding sleeve.</p>	

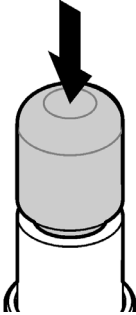
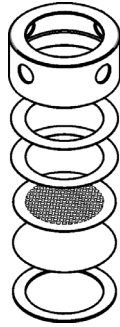
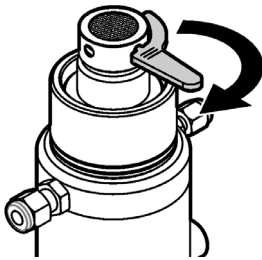
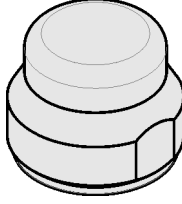
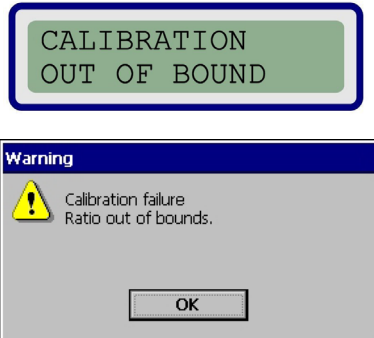
<p>Push the installation tool firmly downwards. This clasps the mounting ring onto the sensor head, folding the membrane(s) over the sensor tip.</p> <p>Remove the installation tool and guiding sleeve.</p> <p>Visually check for correct ring placement, try to push it down with your fingers.</p> <p>Check that the membrane is tight, with no wrinkles.</p> <p>Note: Once installed, a membrane cannot be reused. Avoid touching membranes with bare fingers, as this may affect its sensitivity.</p>	
<p>Prepare the protection cap for installation:</p> <p>All parts must be absolutely dry and clean.</p> <p>Replace all the parts inside the protection cap with new ones (except the grille), and place them in the order they were removed.</p> <p>The Tefzel washers, under the cap, should be slightly lubricated with silicone grease.</p> <p>Note: The illustration on the right is an example only. Your configuration may differ.</p>	
<p>Tighten the protection cap finger tight.</p> <p>Then, complete the process using the tool provided in the maintenance kit. Insert into each of the four holes in turn, and tighten as far as possible. Tighten each hole only once.</p> <p>Note: The grille inside the protection cap should be free to move during tightening. Therefore, and to avoid damage to the membrane, do not touch the grille during the tightening process.</p>	
<p>Always store the sensor in a dry environment, with the storage cap installed (refer to Storage information on page 16).</p>	
<p>Note: A sensor that has been taken apart, or serviced must always be calibrated. Allow the sensor to settle for 30 minutes to allow measurements to stabilize and the membrane(s) to relax, before performing the sensor calibration.</p> <p>Calibrate the sensor to check that the membrane has been installed correctly and not been damaged.</p> <p>If an error message (like those illustrated right) appears on your instrument, then the membrane has been damaged or incorrectly installed.</p>	

Section 6 Spare Parts and Accessories

6.1 Sensor parts

Part N°	Description
28129	Delrin storage cap (sensor's storage cap)
28320	Membrane supporting disc with stainless steel grill. Thermal conductivity sensor
28614	Combined protection cap and membrane holding ring removal tool
29228	Stainless steel membrane holding ring (membrane thickness < 50 μ)
29229	Stainless steel membrane holding ring (membrane thickness > 50 μ)
2935A	Halar membranes, 25 μ m, box of 25.
2952A	Tefzel membranes, 25 μ m. box of 25.
29561A	PFA membranes, 25 μ m. box of 25.
32920	Membrane mounting tool, including centering sleeve and plunger

6.2 Accessories

Part N°	Description
DG33647	Pressure sensor 0-50 PSIA / 0-3.5 bar absolute
29006.0	EPDM O-rings for flow chamber/sensor socket 28x2 and 32x2mm
32605	Safety Purge Backup Unit for TC sensors
32557	External temperature sensor for in-line use, supplied with 4 pin LEMO connector for TC sensors. Sensor socket must be ordered separately.
32559.0	External temperature sensor for off-line use, supplied with 4 pin LEMO connector for TC sensors. T piece for connection to 6mm tubing included.
32559.1	External temperature sensor for off-line use, supplied with 4 pin LEMO connector for TC sensors. T piece for connection to 1/4" tubing included.
32560	External temperature sensor for fitting to Tuchenhagen Varivent with > or = 3 inch diameter (not included) and a TC sensor. Supplied with 1 meter of cable and 4 pin LEMO connector for the TC sensor.
32562	External temperature sensor for use with 32011 flow chamber and a TC sensor. Supplied with a 4 pin LEMO and 1 meter of cable.
32563	External temperature sensor for in-line use, with liquid tight base in stainless steel. Supplied with 4 pin LEMO connector for TC sensors. Sensor socket to be ordered separately.

6.3 Flow chambers and installation devices

Table 10 Flow chambers and installation devices	
Part N°	Description
29501.0	Sensor socket for welding to SS pipe, with EPDM O-ring
29501.1	Sensor socket for welding to SS pipe, with Viton O-ring
32001.010	Flow chamber in stainless steel (316) with 6 mm fittings. Supplied with EPDM O-rings.
32001.011	Flow chamber in stainless steel (316) with ¼" fittings. Supplied with EPDM O-rings.
32001.030	Flow chamber in Delrin with 6 mm fittings. Supplied with EPDM O-rings.
32001.031	Flow chamber in Delrin with ¼" fittings. Supplied with EPDM O-rings.
32001.141	Flow chamber in Hastelloy with ¼" fittings. Supplied with Viton O-rings.
32001.151	Flow chamber in titanium with ¼" fittings (6 mm fittings not available in titanium) Supplied with Viton O-rings.
32001.181	Flow chamber in Kynar with ¼" fittings. Supplied with Viton O-rings.
32001.191	Flow chamber in PTFE with ¼" fittings. Supplied with Viton O-rings.
32002.010	Multi parameter flow chamber in stainless steel with 6 mm fittings. Supplied with EPDM O-rings. For use with the external pressure sensor model DG33647.
32002.011	Multi parameter flow chamber in stainless steel with ¼" fittings. Supplied with EPDM O-rings. For use with the external pressure sensor model DG33647.
32003	ProAcc sensor insertion device ; for use with Tuchenhagen adapter
32011	Flow chamber in acrylic with 1/8" Swagelok fittings for small volume liquid phase measurements, with port for 32562 external temperature sensor.

6.4 Maintenance kits for TC sensors

Table 11 Maintenance kits	
Part N°	Description
32739	Maintenance Kit for high pressure thermal conductivity sensor applications as well as certain hydrogen thermal conductivity cases. Includes membranes 29561A, membrane holding ring 29228.01, kit 29082, and tools for sensor maintenance.
32741	Maintenance Kit for hydrogen thermal conductivity sensors with 29108 protection cap. Includes membranes 2952A, membrane holding ring 29228.01, kit 29082, and tools for sensor maintenance.
32749	Maintenance Kit for carbon dioxide & nitrogen thermal conductivity sensors having the 29108 protection cap. Includes membranes 29561A, membrane holding ring 29228.01, kit 29082 for protection cap, and tools for sensor maintenance.
32760	Maintenance kit for carbon dioxide & nitrogen TC sensors with protection cap 29111. Includes membranes 29561A, membrane holding ring 29228.01, 28002 washers, and tools for sensor maintenance.

6.5 Protection caps and related part kits

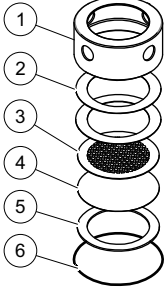
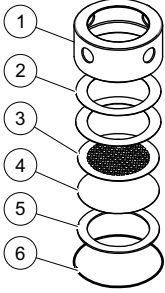
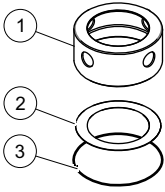
Table 12 Protection caps and related part kits		
Part N°	Protection Cap Design	Specific Spare Parts
29 108	<p>1: Standard protection cap with honeycomb grille.</p> <p>Delivered with 29082 kit.</p>	 <p>Kit 29082 includes:</p> <p>2: 28002 Tefzel washer x 6 (2) 3: 29080 honeycomb grille 4: 29049 Dacron mesh x 10 (1) 5: 28003 silicon washer x 3 (1) 6: 29039.0 EPDM o-ring x 5 (1)</p>
29107.0	<p>1: Standard protection cap with honeycomb grille for humid gases only.</p> <p>Delivered with 29063 kit.</p>	 <p>Kit 29063 includes:</p> <p>2: 28002 Tefzel washer x 6 (2) 3: 29080 honeycomb grille 4: 29031A Water separation filter x 3 (1) 5: 28003 silicon washer x 3 (1) 6: 29039.0 EPDM o-ring x 5 (1)</p>
29 111	<p>1: Protection cap with bonded stainless steel mesh, incl. 1 Tefzel washer.</p>	 <p>Individual parts:</p> <p>2: 28002 Tefzel washers x 6 (1) 3: 29039.0 EPDM o-ring x 5 (1)</p>

Example:

- x 5 means 5 items are supplied
- (1) means only one is required

Note: Depending on the application, O-rings are available in EPDM, Viton®, Kalrez®, Nitril®

HACH COMPANY World Headquarters

P.O. Box 389, Loveland, CO 80539-0389 U.S.A.
Tel. (970) 669-3050
(800) 227-4224 (U.S.A. only)
Fax (970) 669-2932
orders@hach.com
www.hach.com

HACH LANGE GMBH

Willstätterstraße 11
D-40549 Düsseldorf, Germany
Tel. +49 (0) 2 11 52 88-320
Fax +49 (0) 2 11 52 88-210
info-de@hach.com
www.de.hach.com

HACH LANGE Sàrl

6, route de Compois
1222 Vézenaz
SWITZERLAND
Tel. +41 22 594 6400
Fax +41 22 594 6499

