

# Ultra Low Range CL17sc Colorimetric Chlorine Analyzer

## Applications

- Drinking Water
- Wastewater
- Food and Beverage
- Pharmaceutical
- Power
- Semiconductor
- Field Use



## Total chlorine confidence. From the global leader in chlorine analysis.

Meet your unique water cycle needs with the new Ultra Low Range CL17sc online total chlorine analyzer from Hach®. Whether treating utility water, product water, or wastewater discharge, you'll have the direct chlorine measurements you need to optimize your process. You'll be able to protect valuable assets and report to regulatory agencies with confidence.

### Monitor and Optimize your Dechlorination process

Chlorine breakthroughs can adversely affect your process, product, or equipment. You'll be able to mitigate issues and optimize your process with the Hach Ultra Low Range CL17sc analyzer, which has the lowest limit of detection at less than 8 ppb. It's time to accurately measure your total residual chlorine and take control of your dechlorination process.

### Depend on direct measurements

Online residual chlorine measurement options for ultra-low range have been either inadequate or inefficient – until now. The Ultra Low Range CL17sc gives you direct total chlorine results, eliminating the need for ORP or amperometric measurement. The Ultra Low Range CL17sc uses colorimetric DPD Standard Method 4500-Cl G and consistently maintains accuracy without loss of sensitivity in your new target range.

### Protect your assets

Understand the true impact of chlorine exposure. The Ultra Low Range CL17sc allows for process control across your water cycle, including visibility into GAC exhaustion or channeling and dechlorinating agent dosage. It is the only instrument with a cumulative chlorine counter, which helps you forecast your RO membrane efficiency and its useful life.

### Connect with Claros

When the new Ultra Low Range CL17sc analyzer is connected to Claros™, Hach's Water Intelligence system, it provides real-time visibility into your processes so you can optimize and automate your chlorination/dechlorination. You'll have peace of mind and more time to focus on high-value tasks.

## Technical Data\*

<b>Range</b>	0.008 - 5 mg/L Cl <sub>2</sub>
<b>Accuracy</b>	± 5% or ± 0.01 mg/L (whichever is greater) from 0 - 4 mg/L; ± 10% from 4 - 5 mg/L
<b>Lower Limit of Detection (LOD)</b>	0.008 mg/L Cl <sub>2</sub> at 25 °C
<b>Cycle Time</b>	2.5 minutes
<b>Inlet Pressure</b>	0.3 - 5.2 bar (4.5 - 75 psig) supplied to Y-strainer 0.1 - 0.3 bar (1.5 - 5 psig) supplied to analyzer
<b>Inlet</b>	¼-inch OD polyethylene tube, quick-disconnect fitting
<b>Drain</b>	½-inch ID flexible hose
<b>Air Purge</b>	Optional with 3/8-inch quick-connect fitting and tubing; 0.003 m <sup>3</sup> /min at 1.38 bar (20 psig) maximum
<b>Sample Requirements</b>	Y-strainer filtration with 40-mesh screen or higher
<b>Sample Flow Rate</b>	60 - 200 mL/min through the instrument
<b>Sample Temperature</b>	5 - 40 °C (41 - 104 °F)
<b>Operating Temperature Range</b>	5 - 40 °C (41 - 104 °F)
<b>Operating Humidity</b>	0 - 90% relative humidity, non-condensing

<b>Interferences</b>	Other oxidizing agents such as bromide, chlorine dioxide, permanganate, and ozone will cause a positive interference.
<b>Reagent Consumption</b>	0.5 L of buffer solution and 0.5 L of indicator solution in 31 days
<b>Certifications</b>	CE compliant with: EN 61326-1, CISPR 11, EN 50581 ACMA RCM South Korea KC Certificate North America: FCC Supplier's Declaration of Conformance, IEC/EN 60529, ICES-003
<b>Light Source</b>	LED, measurement at 510 nm, 1 cm light pathlength
<b>Enclosure Rating</b>	IP66
<b>Mounting</b>	Wall mount
<b>Power Requirements (Voltage)</b>	12 VDC, 400 mA maximum (supplied by the controller)
<b>Dimensions (H x W x D)</b>	342 mm x 329 mm x 177 mm
<b>Weight</b>	4.1 kg (9.0 lbs.)

\*Subject to change without notice.

## Principle of Operation

The Ultra Low Range CL17sc Colorimetric Chlorine Analyzer has three operating components:

- A linear peristaltic pump to precisely control the volume of incoming samples and reagents
- A colorimeter
- Indicator and buffer solutions

A zero reference point is established at the beginning of the cycle by measuring blank absorbance. (This compensates for the sample's color intensity and turbidity before the chlorine measurement is made.) Indicator and buffer solutions are then added to the sample while a magnetic stirrer mixes the solution and the sample changes color. A colorimeter then measures the light transmitted through the sample. The measured color intensity is compared to a reference standard. Finally, the sample cell is flushed with new sample so that the cycle can repeat every 2.5 minutes.

### Dimensions

The Ultra Low Range CL17sc is designed to be wall-mounted with four ¼-inch screws. Adequate clearance must be left for plumbing and controller connection. The sample inlet connection is a ¼-inch quick-connect fitting and the drain connection is ½-inch ID flexible hose. The analyzer receives power from connection to a Hach SC controller. (The analyzer’s cable is approximately 6.5 ft. in length.)

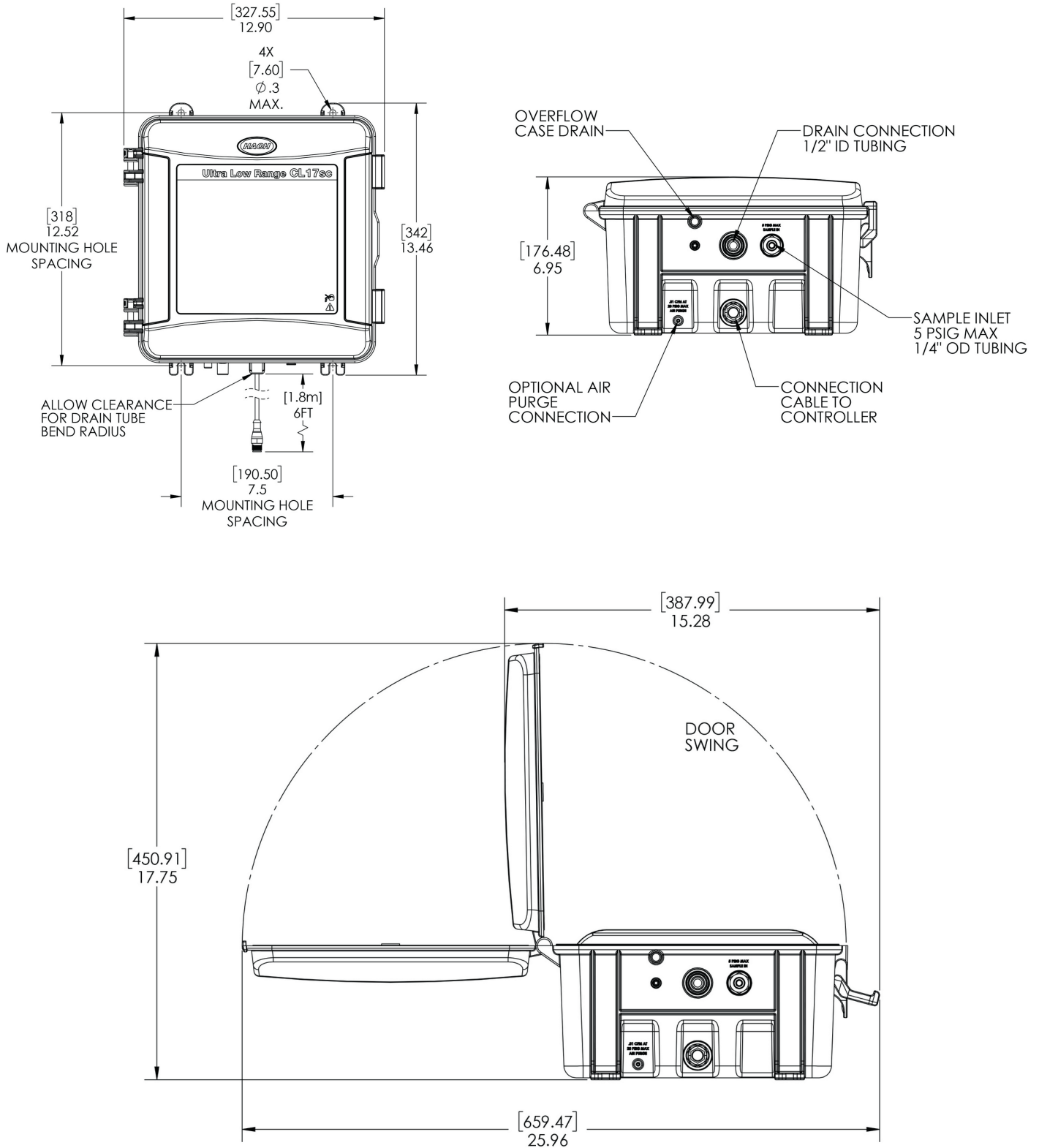

## Order Information

Hach Ultra Low Range CL17sc Colorimetric Chlorine Analyzers are shipped with an installation kit, user manual, and one month of reagents where noted. The user selects a standpipe installation kit or a pressure regulator installation kit at the time of purchase. Hach SC controllers are required for operation and are sold separately.

### Ultra Low Range CL17sc Colorimetric Chlorine Analyzers

- 9790200** Ultra Low Range CL17sc Colorimetric Chlorine Analyzer with Standpipe Installation Kit  
**9790300** Ultra Low Range CL17sc Colorimetric Chlorine Analyzer with Pressure Regulator Installation Kit

### Accessories

- 8568200** CL17sc Calibration Verification Kit  
**8573200** CL17sc Calibration Verification Refill Kit  
**8560500** CL17sc Standpipe Installation Kit  
**8565700** CL17sc Pressure Regulator Installation Kit

### Reagents and Consumables

- 9791100** Ultra Low Range Total Chlorine Reagents Set  
**8560400** CL17sc Tubing Kit (pre-assembled)  
**8573100** CL17sc Cell Cleaning Kit



This instrument connects to Claros, Hach's innovative Water Intelligence System. Claros allows you to seamlessly connect and manage instruments, data, and process – anywhere, anytime. The result is greater confidence in your data and improved efficiencies in your operations. To unlock the full potential of Claros, insist on Claros Enabled instruments.



With Hach Service, you have a global partner who understands your needs and cares about delivering timely, high-quality service you can trust. Our Service Team brings unique expertise to help you maximize instrument uptime, ensure data integrity, maintain operational stability, and reduce compliance risk.

### Hach World Headquarters: Loveland, Colorado USA

United States: 800-227-4224 tel 970-669-2932 fax [orders@hach.com](mailto:orders@hach.com)  
 Outside United States: 970-669-3050 tel 970-461-3939 fax [int@hach.com](mailto:int@hach.com)  
[hach.com](http://hach.com)

Printed in U.S.A.

©Hach Company, 2021. All rights reserved.

*In the interest of improving and updating its equipment, Hach Company reserves the right to alter specifications to equipment at any time.*



Be Right™